

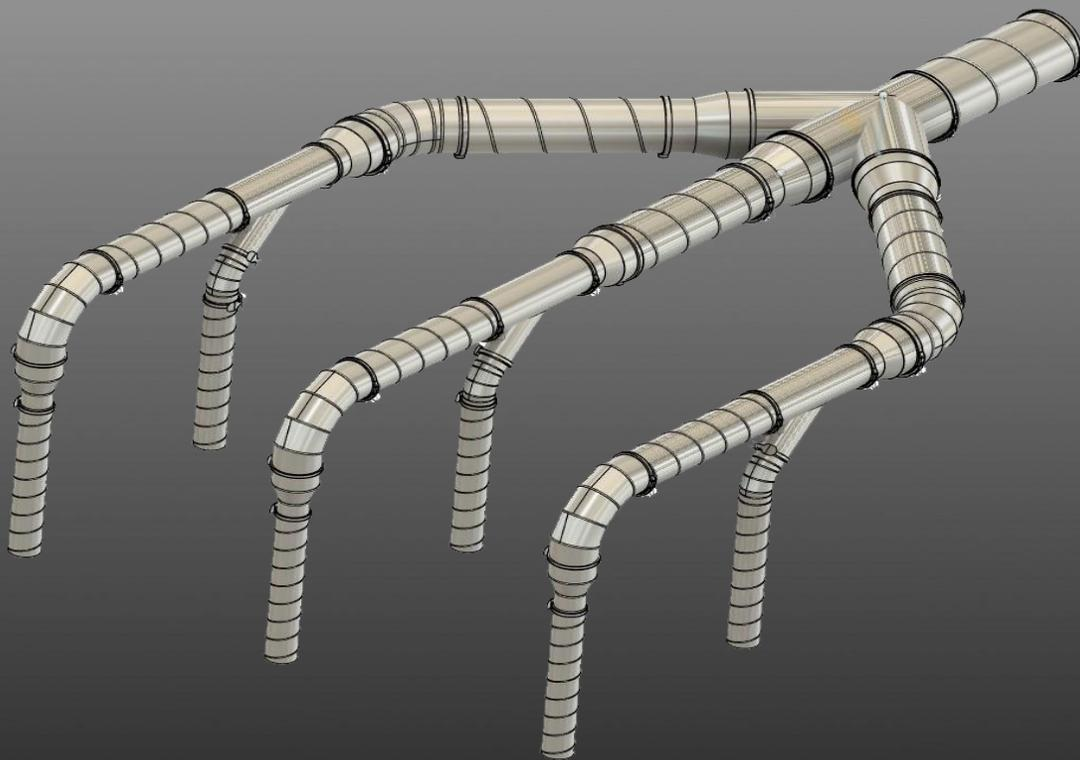

Submittal Information Guide



Contact info: Dave Procratsky

Phone #: 724-880-2022 Email: dave@hranec.com

Dust Duct: Spiral Pipe 100 Series Selections

101 Spiral Pipe with Clamp Connections and Gorelock Fittings

Spiral Pipe with Clamp Connection.....	Page 3
Gorelock Elbows with Clamp Connection	Page 4
Gorelock Reducers with Clamp Connection.....	Page 5
Full Body Takeoffs with Clamp Connection.....	Page 6

102 Spiral Pipe with Clamp Connections and Welded Fittings

Spiral Pipe with Clamp Connection.....	Page 7
Welded Elbows with Clamp Connection.....	Page 8
Welded Reducers with Clamp Connection.....	Page 9
Full Body Takeoffs with Clamp Connection.....	Page 10

103 Spiral Pipe with Angle Ring Connections & Gorelock Fittings

Spiral Pipe with Angle Ring Connection.....	Page 11
Gorelock Elbows with Angle Ring Connection.....	Page 12
Gorelock Reducers with Angle Ring Connection.....	Page 13
Full Body Takeoffs with Angle Ring Connection.....	Page 14

104 Spiral Pipe with Angle Ring Connections & Welded Fittings

Spiral Pipe with Angle Ring Connection.....	Page 15
Welded Elbows with Angle Ring Connection.....	Page 16
Welded Reducers with Angle Ring Connection.....	Page 17
Full Body Takeoffs with Angle Ring Connection.....	Page 18

Dust Duct: Welded Pipe One Seam 200 Series Selections

201 Welded Pipe One Seam with Clamp Connections & Gorelock Fittings

Welded Pipe One Seam with Clamp Connection.....	Page 19
Gorelock Elbows with Clamp Connection.....	Page 20
Gorelock Reducers with Clamp Connection.....	Page 21
Full Body Takeoffs Clamp Connection.....	Page 22

202 Welded Pipe One Seam with Clamp Connections & Welded Fittings

Welded Pipe One Seam with Clamp Connection.....	Page 23
Welded Elbows with Clamp Connection.....	Page 24
Welded Reducers with Clamp Connection.....	Page 25
Full Body Takeoffs with Clamp Connection.....	Page 26

203 Welded Pipe One Seam with Welded Connections and Welded Fittings

Welded Pipe One Seam with Welded Connection.....	Page 27
Welded Elbows with Welded Connection.....	Page 28
Welded Reducers with Welded Connection.....	Page 29
Full Body Takeoffs with Welded Connection.....	Page 30

204 Welded Pipe One Seam with Angle Ring Connections and Welded Fittings

Welded Pipe One Seam with Angle Ring Connection.....	Page 31
Welded Elbows with Angle Ring Connection.....	Page 32
Welded Reducers with Angle Ring Connection.....	Page 33
Full Body Takeoffs with Angle Ring Connection.....	Page 34

Accessories & Data

Blast Gates, Floor Sweeps, Flexible Duct.....	Page 35
TESTING: Pressure Test Data.....	Page 36
CAD Drawings.....	Page

Dust Duct 101

SPIRAL PIPE with Clamp Connection

Pressure Class Rating: Negative 10" Water Gauge Max

Sizes Available: Odd sizes: 5", 7", and 9", Even Sizes: 4" through 18"

Lengths Available: 6" through 120", custom lengths from 120" to 240" are also available

Material Available: Standard Galvanized G90, however 304 and 316 stainless steels are available.

Fabrication: 5.394" wide slit coil material is manufactured into a rigid spiral steel tube with a 4-ply lock seam. The grooved seam material is formed on the outside which creates a smooth inside low friction loss inside the tube.

Connection: Straight Spiral pipe and fittings come with a 1/4" rolled out lip. Each spiral section comes with an insert that is removable making each piece of straight spiral pipe adjustable if needed. Then the clamp connection is easily installed creating a strong and airtight connection. Connection Clamp material is zinc plated with gasket material, ethylene propylene diene monomer (EPDM). There are no screws required to make the connections, which eliminates screw threads on the inside of the pipe and fittings.

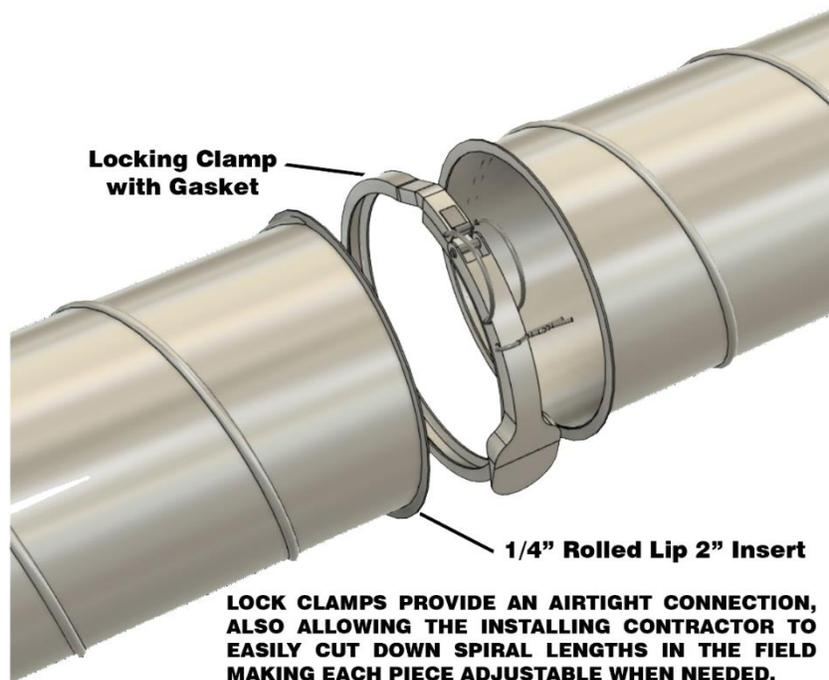

Dust Duct 101

Spiral Pipe with Clamp Connection

GORELOCK ELBOW with Clamp Connection

Pressure Class Rating: Negative 10" Water Gauge Max

Sizes Available: Odd sizes: 5", 7", and 9", Even Sizes: 6" through 18"

Material Available: Standard Galvanized G90, however 304 and 316 stainless steels are available.

Fabrication: Elbows are available at any angle. Standard segmented elbows have a gorelock transverse seam and a stitch welded longitudinal seam. Radius is standard 1.5x centerline although any radius is available.

Connection: Elbows come with a 1/4" rolled out lip. The clamp connection is easily installed creating a strong and airtight connection. Connection Clamp material is zinc plated with gasket material, ethylene propylene diene monomer (EPDM). There are no screws required to make the connections, which eliminates screw threads on the inside of the pipe and fittings.

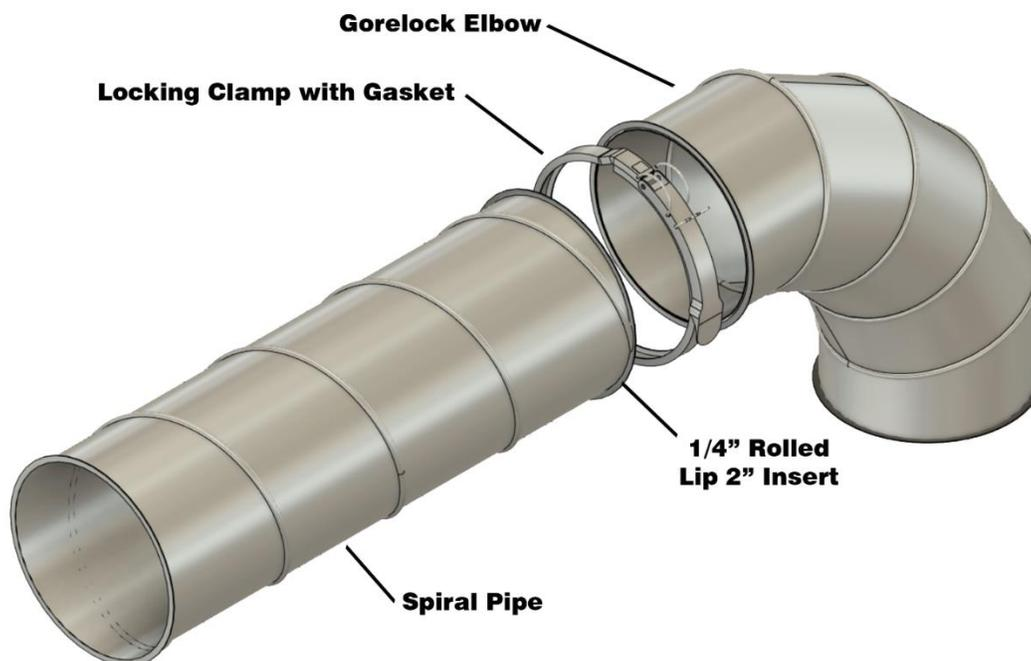

Dust Duct 101

Spiral Pipe with Clamp Connection

GORELOCK REDUCER with Clamp Connection

Pressure Class Rating: Negative 10" Water Gauge Max

Sizes Available: Odd sizes: 5", 7", and 9", Even Sizes: 6" through 18"

Material Available: Standard Galvanized G90, however 304 and 316 stainless steels are available.

Lengths Available: Length of a reducer is determined by the set of the reducer. Length is equal to 3 times the largest set, 4" minimum.

Fabrication: Reducers are made with stitch welded longitudinal seams and with gorelock collars. Standard reducers are concentric, however eccentric and offsetting reducers are available.

Connection: Reducers come with a 1/4" rolled out lip. The clamp connection is easily installed creating a strong and airtight connection. Connection Clamp material is zinc plated with gasket material, ethylene propylene diene monomer (EPDM). There are no screws required to make the connections, which eliminates screw threads on the inside of the pipe and fittings.

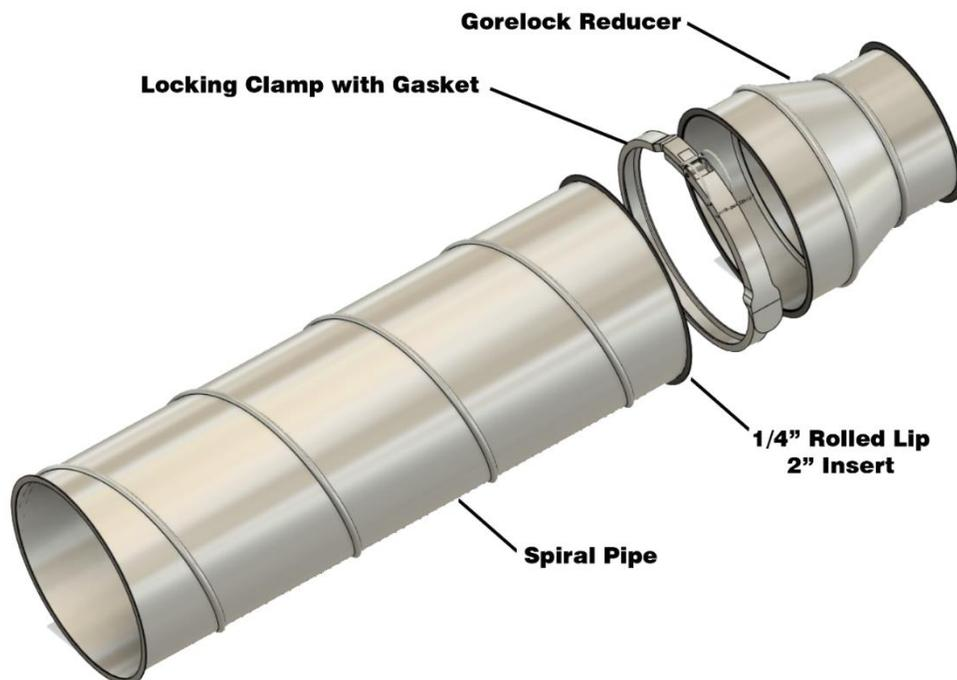

Dust Duct 101

Spiral Pipe with Clamp Connection

FULL BODY TAKEOFF with Clamp Connection

Pressure Class Rating: Negative 10" Water Gauge Max

Sizes Available: Odd sizes: 5", 7", and 9", Even Sizes: 4" through 18"

Material Available: Standard Galvanized G90, however 304 and 316 stainless steels are available.

Lengths Available: Length of tees and crosses are determined by the diameter of the branch.

Fabrication: Lateral 45 degree tees and crosses are the typical side take off, however branches can come off at any angle. Tees and crosses are tack welded with sealed seams. This fitting can be used to reduce the system's main truck line.

Connection: Tees and Crosses come with a 1/4" rolled out lip. The clamp connection is easily installed creating a strong and airtight connection. Connection Clamp material is zinc plated with gasket material, ethylene propylene diene monomer (EPDM). There are no screws required to make the connections, which eliminates screw threads on the inside of the pipe and fittings.

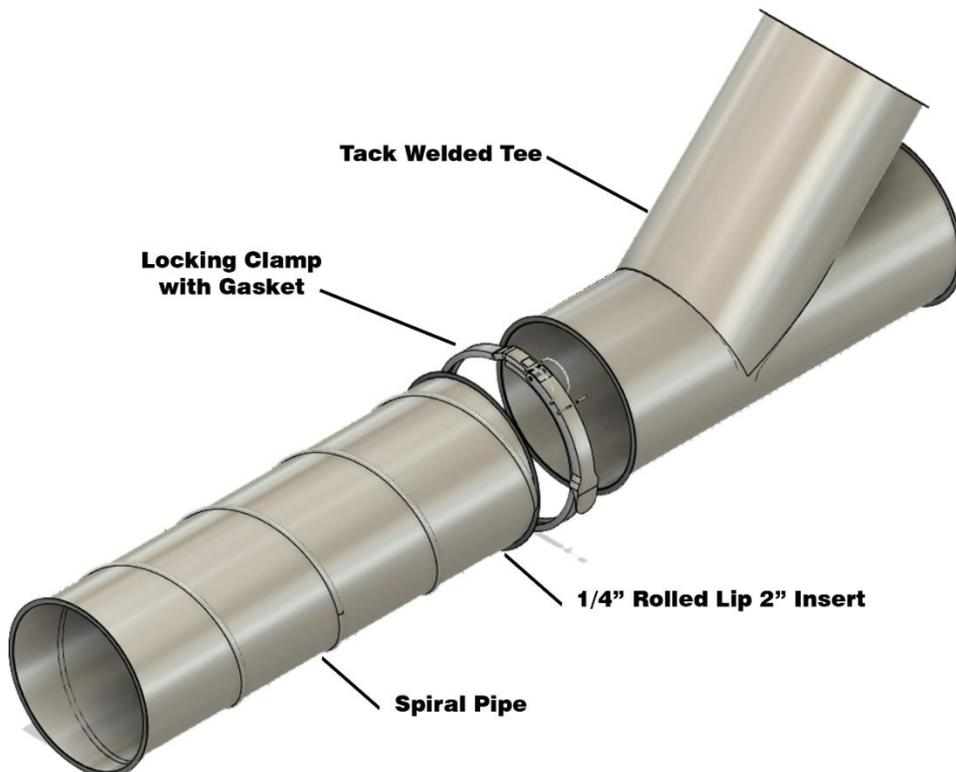

Dust Duct 102

SPIRAL PIPE with Clamp Connection

Pressure Class Rating: Negative 10" Water Gauge Max

Sizes Available: Odd sizes: 5", 7", and 9", Even Sizes: 4" through 18"

Lengths Available: 6" through 120", custom lengths from 120" to 240" are also available

Material Available: Standard Galvanized G90, however 304 and 316 stainless steels are available.

Fabrication: 5.394" wide slit coil material is manufactured into a rigid spiral steel tube with a 4-ply lock seam. The grooved seam material is formed on the outside which creates a smooth inside low friction loss inside the tube.

Connection: Straight Spiral pipe and fittings come with a 1/4" rolled out lip. Each spiral section comes with an insert that is removable making each piece of straight spiral pipe adjustable if needed. Then the clamp connection is easily installed creating a strong and airtight connection. Connection Clamp material is zinc plated with gasket material, ethylene propylene diene monomer (EPDM). There are no screws required to make the connections, which eliminates screw threads on the inside of the pipe and fittings.

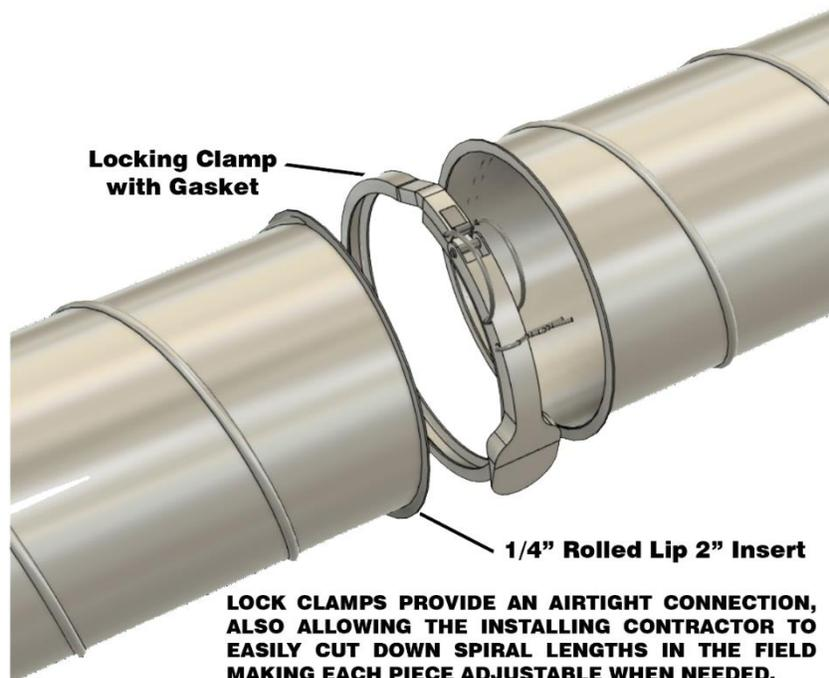

Dust Duct 102

Spiral Pipe with Clamp Connection

WELDED ELBOW with Clamp Connection

Pressure Class Rating: Negative 10" Water Gauge Max

Sizes Available: Odd sizes: 5", 7", and 9", Even Sizes: 4" through 18"

Material Available: Standard Galvanized G90, 304 and 316 stainless steels are available.

Fabrication: Elbows are available at any angle. Segmented elbows have a welded transverse seam and a welded longitudinal seam. Radius is standard 1.5x centerline although any radius is available.

Connection: Elbows come with a 1/4" rolled out lip. The clamp connection is easily installed creating a strong and airtight connection. Connection Clamp material is zinc plated with gasket material, ethylene propylene diene monomer (EPDM). There are no screws required to make the connections, which eliminates screw threads on the inside of the pipe and fittings.

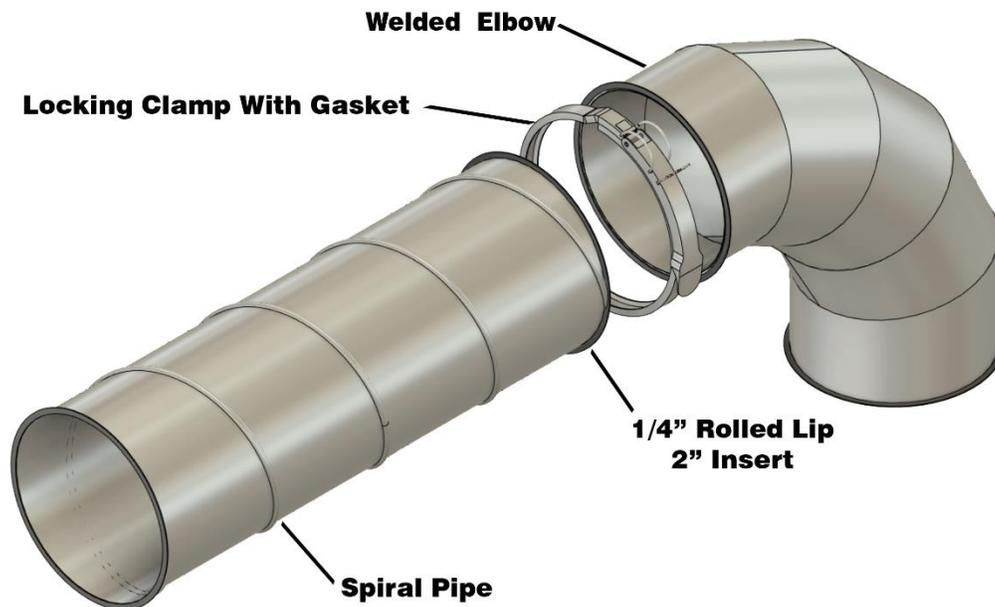

Dust Duct 102

Spiral Pipe with Clamp Connection

WELDED REDUCER with Clamp Connection

Pressure Class Rating: Negative 10" Water Gauge Max

Sizes Available: Odd sizes: 5", 7", and 9", Even Sizes: 4" through 18"

Material Available: Standard Galvanized G90, however 304 and 316 stainless steels are available.

Lengths Available: Length of the reducer is determined by the set of the reducer. Length is equal to 3 times the largest set, 4" minimum.

Fabrication: Reducers are made with welded longitudinal seams and with welded collars. Standard reducers are concentric, however eccentric and offsetting reducers are available.

Connection: Reducers come with a 1/4" rolled out lip. The clamp connection is easily installed creating a strong and airtight connection. Connection Clamp material is zinc plated with gasket material, ethylene propylene diene monomer (EPDM). There are no screws required to make the connections, which eliminates screw threads on the inside of the pipe and fittings.

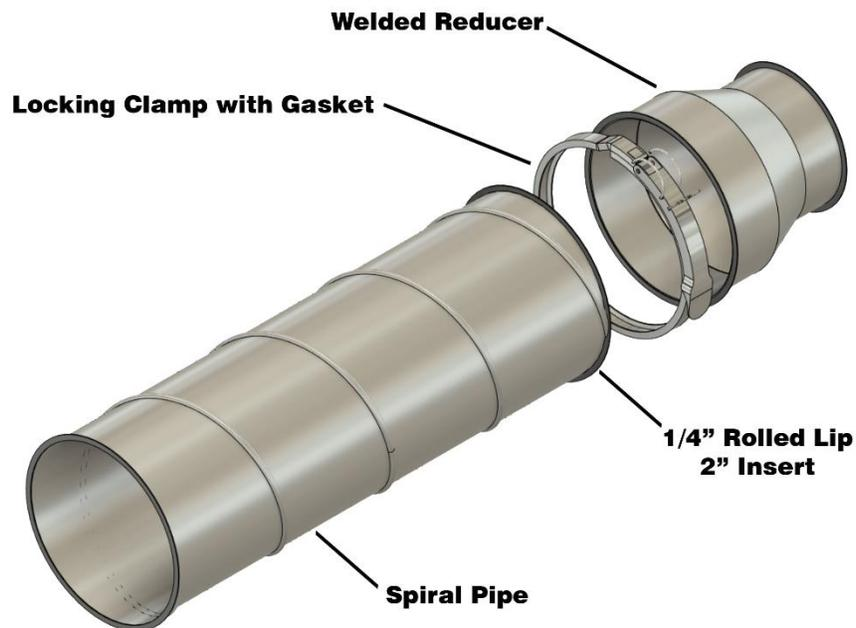

Dust Duct 102

Spiral Pipe with Clamp Connection

FULL BODY TAKEOFF with Clamp Connection

Pressure Class Rating: Negative 10" Water Gauge Max

Sizes Available: Odd sizes: 5", 7", and 9", Even Sizes: 4" through 18"

Material Available: Standard Galvanized G90, however 304 and 316 stainless steels are available.

Lengths Available: Length of tees and crosses are determined by the diameter of the branch.

Fabrication: Lateral 45 degree tees and crosses are the typical side take off, however branches can come off at any angle. Tees and crosses have welded seams. This fitting can be used to reduce the system's main truck line.

Connection: Tees and Crosses come with a 1/4" rolled out lip. The clamp connection is easily installed creating a strong and airtight connection. Connection Clamp material is zinc plated with gasket material, ethylene propylene diene monomer (EPDM). There are no screws required to make the connections, which eliminates screw threads on the inside of the pipe and fittings.

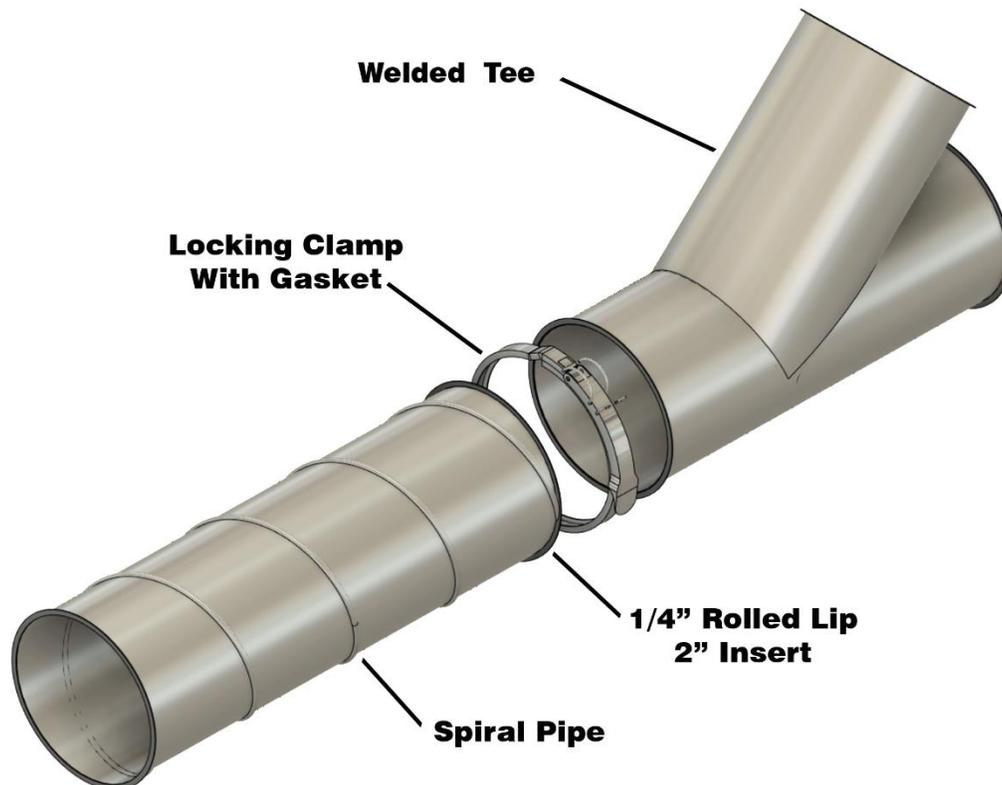

Dust Duct 103

SPIRAL PIPE with Angle Ring Connection

Pressure Class Rating: Negative 20" Water Gauge Max

Sizes Available: Odd sizes: 5", 7", and 9", Even Sizes: 4" through 50"

Lengths Available: 6" through 120"

Material Available: Standard Galvanized G90, 304 and 316 stainless steels are available.

Fabrication: 5.394" wide slit coil material is manufactured into a rigid spiral steel tube with a 4-ply lock seam. The grooved seam material is formed on the outside which creates a smooth inside low friction loss inside the tube.

Connection: Angle rings are tack welded onto the spiral pipe sections. Angle rings have pre punched bolt holes. Connections are made by using neoprene gasket between joining flanges and bolting them together. Angle rings are available to match the ductwork material.

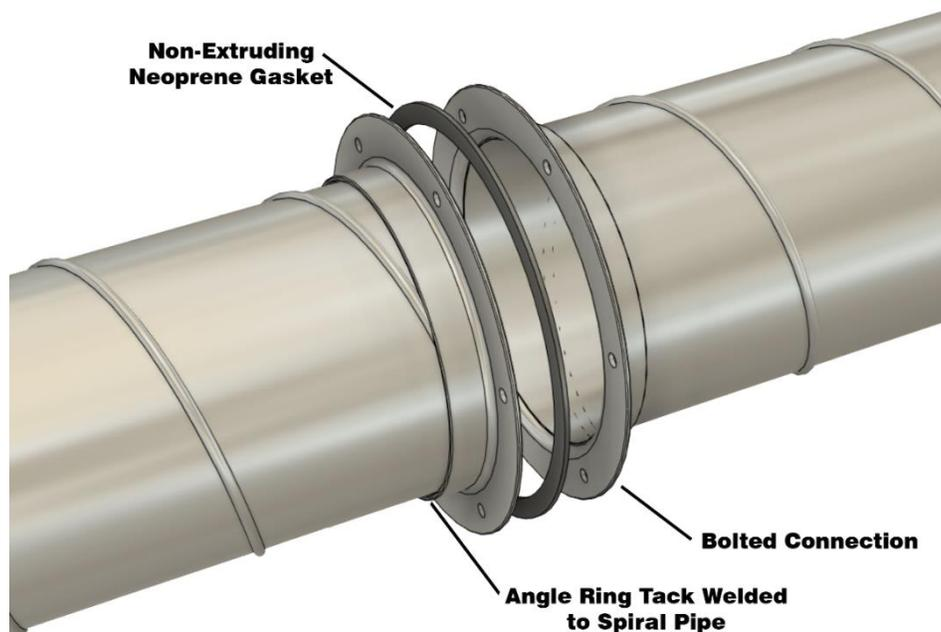

Dust Duct 103

Spiral Pipe with Angle Ring Connection

GORELOCK ELBOW with Angle Ring Connection

Pressure Class Rating: Negative 20" Water Gauge Max

Sizes Available: Odd sizes: 5", 7", and 9", Even Sizes: 6" through 50"

Material Available: Standard Galvanized G90, however 304 and 316 stainless steels are available.

Fabrication: Elbows are available at any angle. Standard segmented elbows have a gorelock transverse seam and a stitch welded longitudinal seam. Radius is standard 1.5x centerline although any radius is available.

Connection: An angle ring will be held on the connection of the elbow with a ½" Vanstone flange. This keeps the angle ring in place but also allows it to spin freely to line it up with the pre punched bolt holes of connecting piece. Neoprene gasket is used between the two joining rings and then the rings are bolted together.

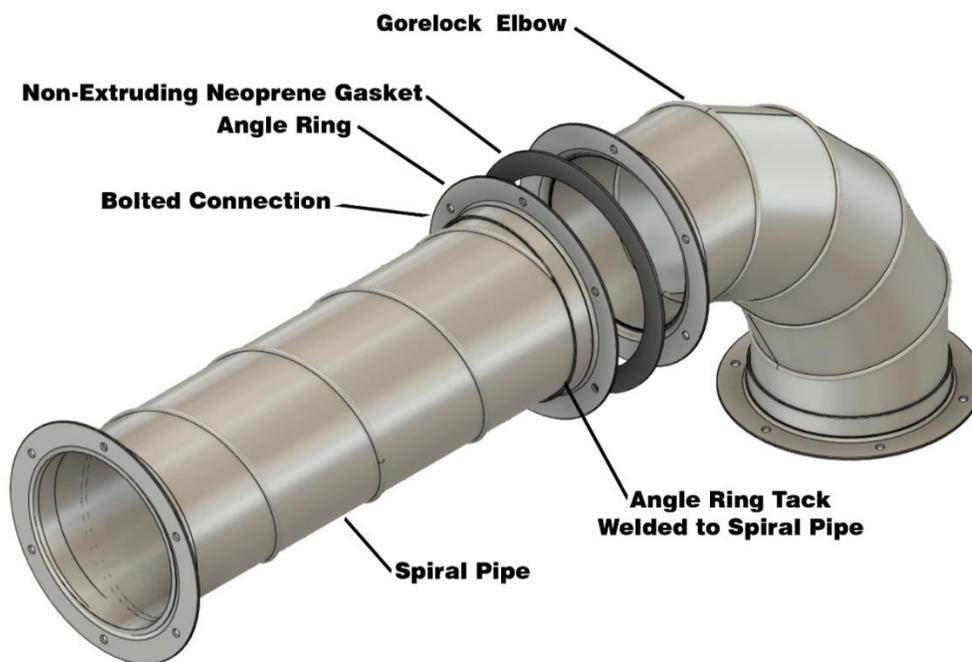

Dust Duct 103

Spiral Pipe with Angle Ring Connection

GORELOCK REDUCER with Angle Ring Connection

Pressure Class Rating: Negative 20" Water Gauge Max

Sizes Available: Odd sizes: 5", 7", and 9", Even Sizes: 6" through 50"

Material Available: Standard Galvanized G90, however 304 and 316 stainless steels are available.

Lengths Available: Length of the reducer is determined by the set of the reducer. Length is equal to 3 times the largest set, 4" minimum.

Fabrication: Reducers are made with stitch welded longitudinal seams and with gorelock collars. Standard reducers are concentric, however eccentric and offsetting reducers are available.

Connection: An angle ring will be placed on the ends of the reducer with a ½" Vanstone flange. This keeps the angle ring in place but also allows it to spin freely in order to line up the pre punched bolt holes. Neoprene gasket is used between two joining rings and then the rings are bolted together.

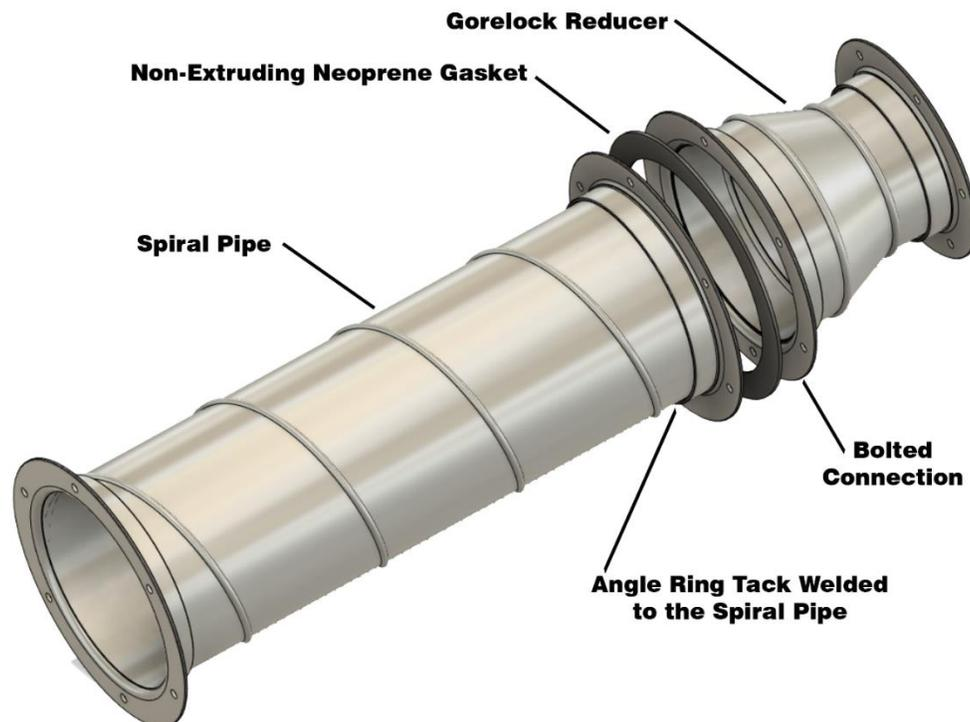

Dust Duct 103

Spiral Pipe with Angle Ring Connection

FULL BODY TAKEOFF with Angle Ring Connection

Pressure Class Rating: Negative 20" Water Gauge Max

Sizes Available: Odd sizes: 5", 7", and 9", Even Sizes: 6" through 50"

Material Available: Standard Galvanized G90, however 304 and 316 stainless steels are available.

Lengths Available: Length of tees and crosses is determined by the diameter of the branching duct.

Fabrication: Lateral 45 degree tees and crosses are the typical side take off, however branches can come off at any angle. Tees and crosses are tack welded with sealed seams. This fitting can be used to reduce the system's main truck line.

Connection: An angle ring will be placed on the ends of the tee with a 1/2" Vanstone flange. This keeps the angle ring in place but also allows it to spin freely in order to line up the pre punched bolt holes. Neoprene gasket is used between two joining rings and then the rings are bolted together.

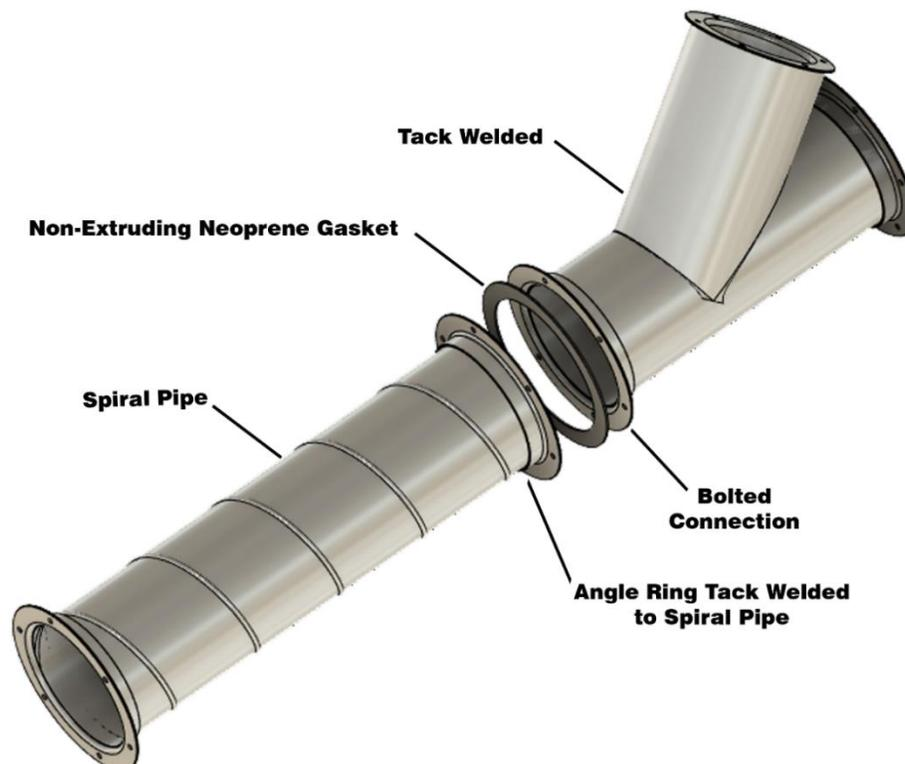

Dust Duct 104

SPIRAL PIPE with Angle Ring Connection

Pressure Class Rating: Negative 20" Water Gauge Max

Sizes Available: Odd sizes: 5", 7", and 9", Even Sizes: 4" through 70"

Lengths Available: 6" through 120"

Material Available: Standard Galvanized G90, 304 and 316 stainless steels are available.

Fabrication: 5.394" wide slit coil material is manufactured into a rigid spiral steel tube with a 4-ply lock seam. The grooved seam material is formed on the outside which creates a smooth inside low friction loss inside the tube.

Connection: Angle rings are tack welded onto the spiral pipe sections. Angle rings have pre punched bolt holes. Connections are made by using neoprene gasket between joining flanges and bolting them together. Angle rings are available to match the ductwork material.

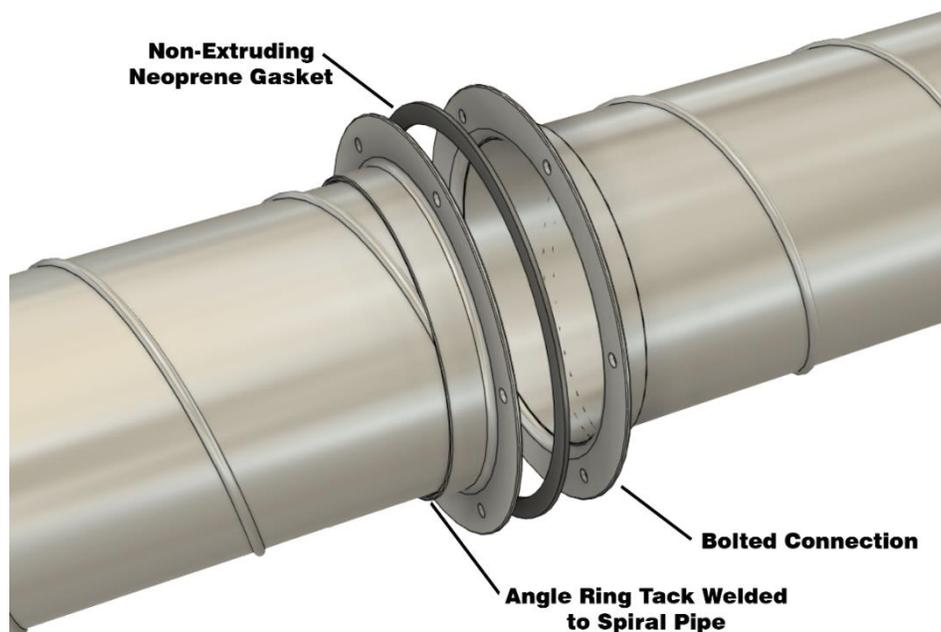

Dust Duct 104

Spiral Pipe with Angle Ring Connection

WELDED ELBOW with Angle Ring Connection

Pressure Class Rating: Negative 30" Water Gauge Max

Sizes Available: Odd sizes: 5", 7", and 9", Even Sizes: 4" through 70"

Material Available: Standard Galvanized G90, however 304 and 316 stainless steels are available.

Fabrication: Elbows are available at any angle. Segmented elbows have a welded transverse seam and a welded longitudinal seam. Radius is standard 1.5x centerline although any radius is available.

Connection: An angle ring will be held on the connection of the elbow with a ½" Vanstone flange. This keeps the angle ring in place but also allows it to spin freely to line it up with the pre punched bolt holes of connecting piece. Neoprene gasket is used between the two joining rings and then the rings are bolted together.

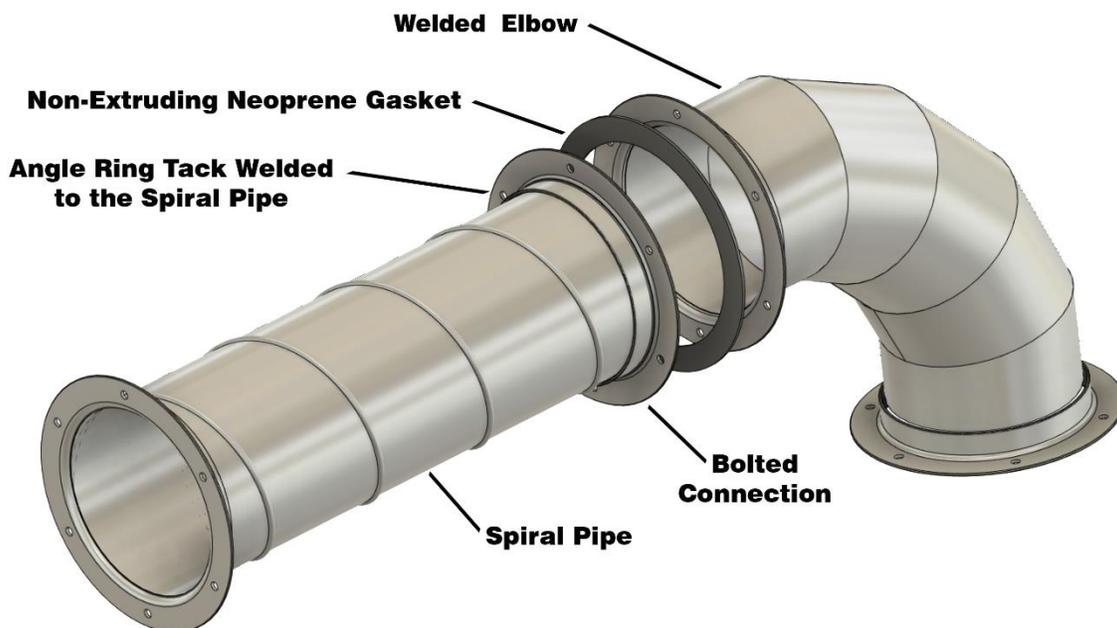

Dust Duct 104

Spiral Pipe with Angle Ring Connection

WELDED REDUCER with Angle Ring Connection

Pressure Class Rating: Negative 30" Water Gauge Max

Sizes Available: Odd sizes: 5", 7", and 9", Even Sizes: 4" through 70"

Material Available: Standard Galvanized G90, however 304 and 316 stainless steels are available.

Lengths Available: Length of the reducer is determined by the set of the reducer. Length is equal to 3 times the largest set, 4" minimum.

Fabrication: Reducers are made with welded longitudinal seams and with welded collars. Standard reducers are concentric, however eccentric and offsetting reducers are available.

Connection: An angle ring will be placed on the ends of the reducer with a ½" Vanstone flange. This keeps the angle ring in place but also allows it to spin freely in order to line up the pre punched bolt holes. Neoprene gasket is used between two joining rings and then the rings are bolted together.

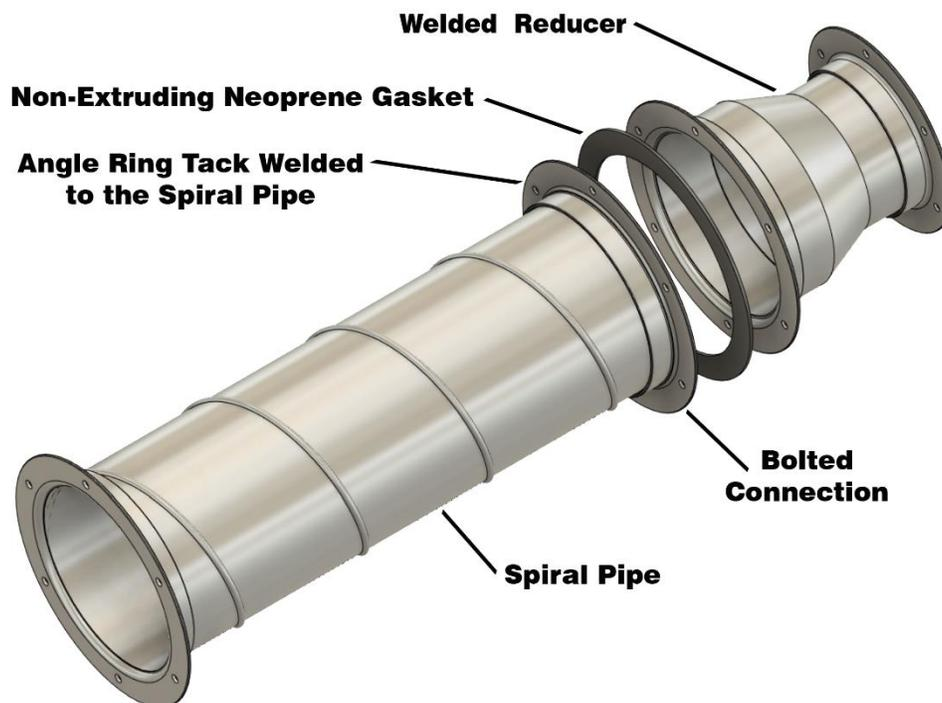

Dust Duct 104

Spiral Pipe with Angle Ring Connection

FULL BODY TAKEOFF with Angle Ring Connection

Pressure Class Rating: Negative 30" Water Gauge Max

Sizes Available: Odd sizes: 5", 7", and 9", Even Sizes: 4" through 70"

Material Available: Standard Galvanized G90, however 304 and 316 stainless steels are available.

Lengths Available: Length of tees and crosses is determined by the diameter of the branching duct.

Fabrication: Lateral 45 degree tees and crosses are the typical side take off, however branches can come off at any angle. Tees and crosses have welded seams. This fitting can be used to reduce the system's main truck line.

Connection: An angle ring will be placed on the ends of the tee with a ½" Vanstone flange. This keeps the angle ring in place but also allows it to spin freely in order to line up the pre punched bolt holes. Neoprene gasket is used between two joining rings and then the rings are bolted together.

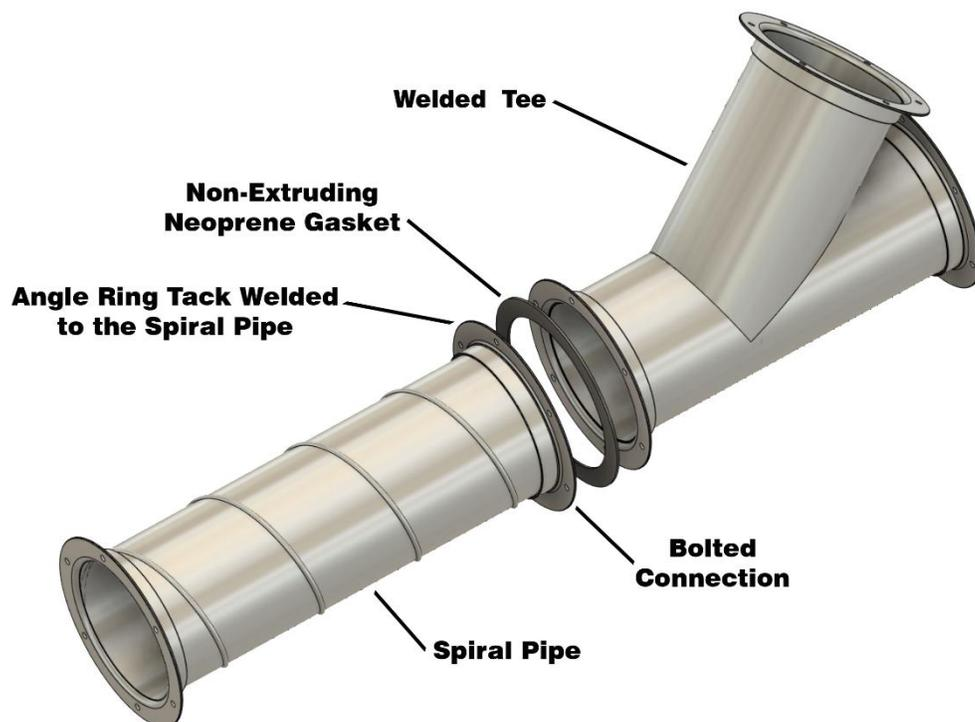

Dust Duct 201

WELDED PIPE ONE SEAM with Clamp Connection

Pressure Class Rating: Negative 10" Water Gauge Max

Sizes Available: Odd sizes: 5", 7", and 9", Even Sizes: 4" through 18"

Lengths Available: 6" through 59½"

Material Available: Standard Galvanized G90, however 304 and 316 stainless steels are available.

Fabrication: Sheets of metal are cut per diameter stretch out at 5' lengths. Then rolled into desired diameters, creating a solid round tube with one longitudinal seam which is butted up, tack welded on 4 inch centers, and then fully welded. A ¼ inch lip is rolled out on each end of the pipe to accept the clamp connection.

Connection: Straight sections and fittings come with a ¼" rolled out lip, butting up the straight sections and fittings to accept the clamp on connection. The clamp connection is easily installed creating a strong and airtight connection. Connection Clamp material is zinc plated with gasket material, ethylene propylene diene monomer (EPDM). There are no screws required to make the connections, which eliminates screw threads on the inside of the pipe and fittings

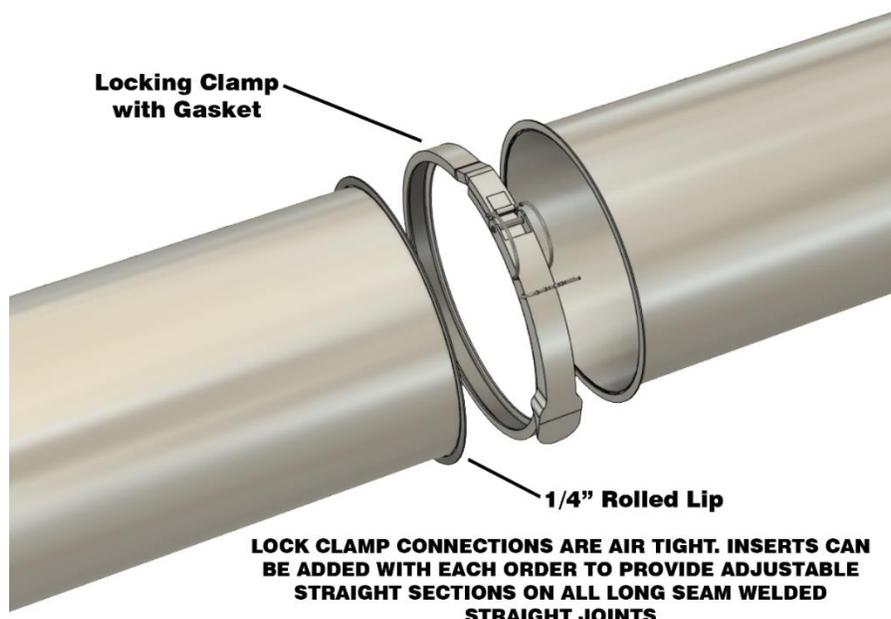

Dust Duct 201

Welded Pipe One Seam with Clamp Connection

GORELOCK ELBOW with Clamp Connection

Pressure Class Rating: Negative 10" Water Gauge Max

Sizes Available: Odd sizes: 5", 7", and 9", Even Sizes: 6" through 18"

Material Available: Standard Galvanized G90, however 304 and 316 stainless steels are available.

Fabrication: Elbows are available at any angle. Standard segmented elbows have a gorelock transverse seam and a stitch welded longitudinal seam. Radius is standard 1.5x centerline although any radius is available.

Connection: Elbows come with a 1/4" rolled out lip. The clamp connection is easily installed creating a strong and airtight connection. Connection Clamp material is zinc plated with gasket material, ethylene propylene diene monomer (EPDM). There are no screws required to make the connections, which eliminates screw threads on the inside of the pipe and fittings.



Dust Duct 201

Welded Pipe One Seam with Clamp Connection

GORELOCK REDUCER with Clamp Connection

Pressure Class Rating: Negative 10" Water Gauge Max

Sizes Available: Odd sizes: 5", 7", and 9", Even Sizes: 6" through 18"

Material Available: Standard Galvanized G90, however 304 and 316 stainless steels are available.

Lengths Available: Length of the reducer is determined by the set of the reducer. Length is equal to 3 times the largest set, 4" minimum.

Fabrication: Reducers are made with stitch welded longitudinal seams and with gorelock collars. Standard reducers are concentric, however eccentric and offsetting reducers are available.

Connection: Reducers come with a 1/4" rolled out lip. The clamp connection is easily installed creating a strong and airtight connection. Connection Clamp material is zinc plated with gasket material, ethylene propylene diene monomer (EPDM). There are no screws required to make the connections, which eliminates screw threads on the inside of the pipe and fittings.

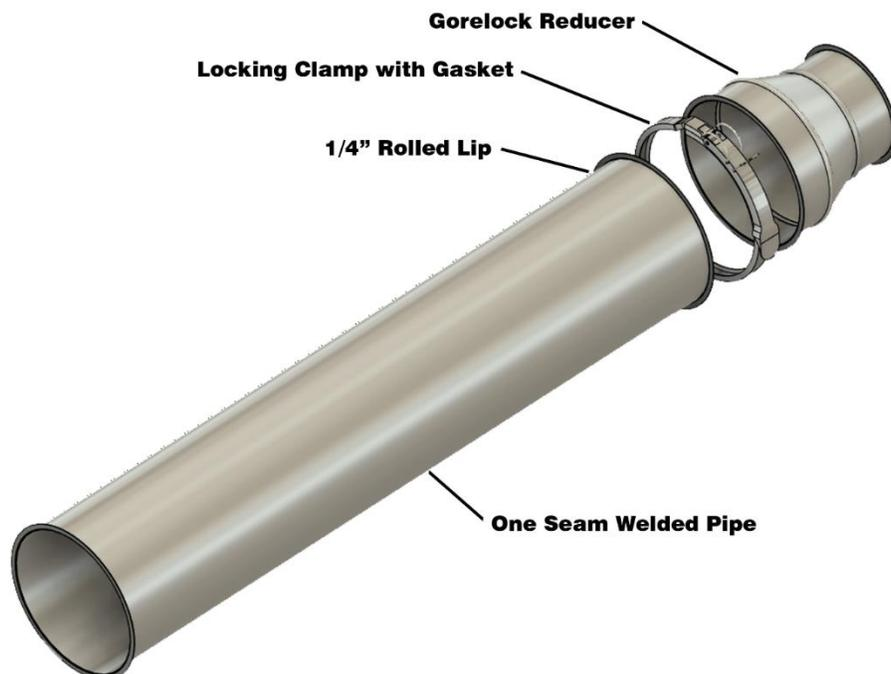

Dust Duct 201

Welded Pipe One Seam with Clamp Connection

FULL BODY TAKEOFF with Clamp Connection

Pressure Class Rating: Negative 10" Water Gauge Max

Sizes Available: Odd sizes: 5", 7", and 9", Even Sizes: 4" through 18"

Material Available: Standard Galvanized G90, however 304 and 316 stainless steels are available.

Lengths Available: Length of tees and crosses are determined by the diameter of the branch.

Fabrication: Lateral 45 degree tees and crosses are the typical side take off, however branches can come off at any angle. Tees and crosses have welded seams. This fitting can be used to reduce the system's main truck line.

Connection: Tees and Crosses come with a 1/4" rolled out lip. The clamp connection is easily installed creating a strong and airtight connection. Connection Clamp material is zinc plated with gasket material, ethylene propylene diene monomer (EPDM). There are no screws required to make the connections, which eliminates screw threads on the inside of the pipe and fittings.

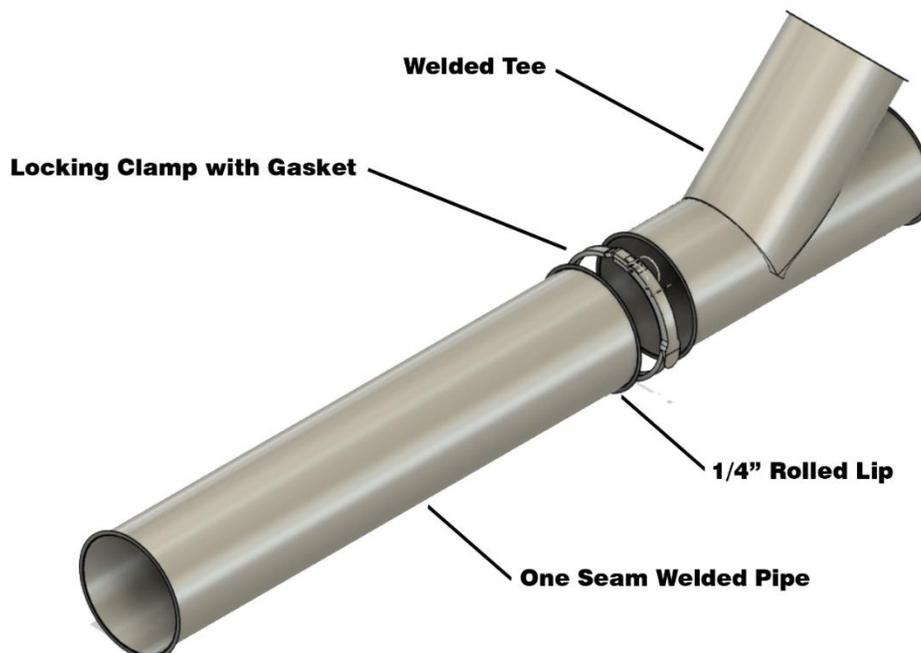

Dust Duct 202

WELDED PIPE ONE SEAM with Clamp Connections

Pressure Class Rating: Negative 10" Water Gauge Max

Sizes Available: Odd sizes: 3", 5", 7", and 9", Even Sizes: 4" through 18"

Lengths Available: 6" through 59½"

Material Available: Standard Galvanized G90, however 304 and 316 stainless steels are available.

Fabrication: Sheets of metal are cut per diameter stretch out at 5' lengths. Then rolled into desired diameters, creating a solid round tube with one longitudinal seam which is butted up, tack welded on 4 inch centers, and then fully welded. A ¼ inch lip is rolled out on each end of the pipe to accept the clamp connection.

Connection: Straight sections and fittings come with a ¼" rolled out lip, butting up the straight sections and fittings to accept the clamp on connection. The clamp connection is easily installed creating a strong and airtight connection. Connection Clamp material is zinc plated with gasket material, ethylene propylene diene monomer (EPDM). There are no screws required to make the connections, which eliminates screw threads on the inside of the pipe and fittings

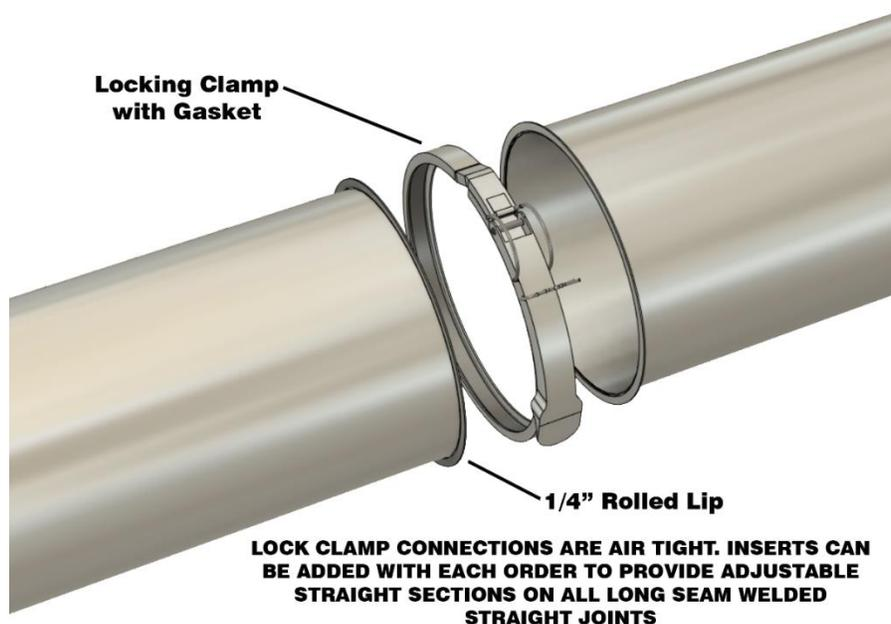

Dust Duct 202

Welded Pipe One Seam with Clamp Connection

WELDED ELBOW with Clamp Connection

Pressure Class Rating: Negative 10" Water Gauge Max

Sizes Available: Odd sizes: 3", 5", 7", and 9", Even Sizes: 6" through 18"

Material Available: Standard Galvanized G90, black iron, 304 and 316 stainless steels are available.

Fabrication: Elbows are available at any angle. Segmented elbows have a welded transverse seam and a welded longitudinal seam. Radius is standard 1.5x centerline although any radius is available.

Connection: Elbows come with a 1/4" rolled out lip. The clamp connection is easily installed creating a strong and airtight connection. Connection Clamp material is zinc plated with gasket material, ethylene propylene diene monomer (EPDM). There are no screws required to make the connections, which eliminates screw threads on the inside of the pipe and fittings.

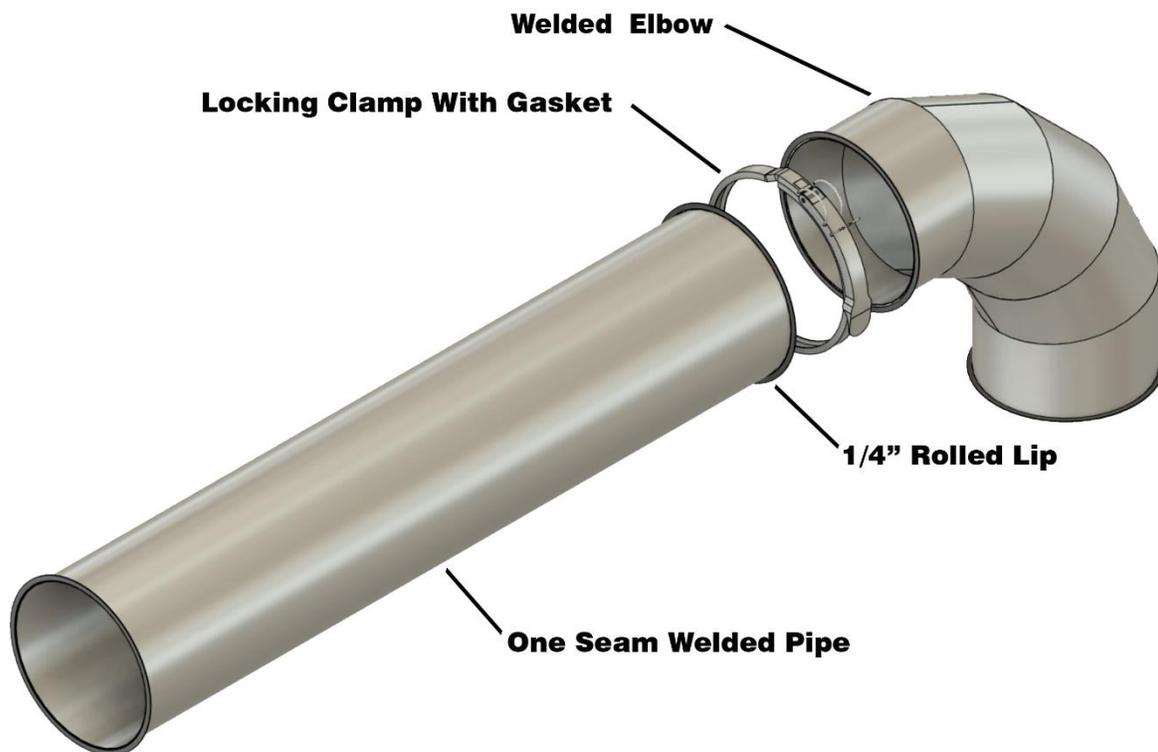

Dust Duct 202

Welded Pipe One Seam with Clamp Connection

WELDED REDUCER with Clamp Connection

Pressure Class Rating: Negative 10" Water Gauge Max

Sizes Available: Odd sizes: 3", 5", 7", and 9", Even Sizes: 6" through 18"

Material Available: Standard Galvanized G90, however 304 and 316 stainless steels are available.

Lengths Available: Length of the reducer is determined by the set of the reducer. Length is equal to 3 times the largest set, 4" minimum.

Fabrication: Reducers are made with welded longitudinal seams and with welded collars. Standard reducers are concentric, however eccentric and offsetting reducers are available.

Connection: Reducers come with a 1/4" rolled out lip. The clamp connection is easily installed creating a strong and airtight connection. Connection Clamp material is zinc plated with gasket material, ethylene propylene diene monomer (EPDM). There are no screws required to make the connections, which eliminates screw threads on the inside of the pipe and fittings.



Dust Duct 202

Welded Pipe One Seam with Clamp Connection

FULL BODY TAKEOFF with Clamp Connection

Pressure Class Rating: Negative 10" Water Gauge Max

Sizes Available: Odd sizes: 3", 5", 7", and 9", Even Sizes: 4" through 18"

Material Available: Standard Galvanized G90, however 304 and 316 stainless steels are available.

Lengths Available: Length of tees and crosses are determined by the diameter of the branch.

Fabrication: Lateral 45 degree tees and crosses are the typical side take off, however branches can come off at any angle. Tees and crosses have welded seams. This fitting can be used to reduce the system's main truck line.

Connection: Tees and Crosses come with a 1/4" rolled out lip. The clamp connection is easily installed creating a strong and airtight connection. Connection Clamp material is zinc plated with gasket material, ethylene propylene diene monomer (EPDM). There are no screws required to make the connections, which eliminates screw threads on the inside of the pipe and fittings.

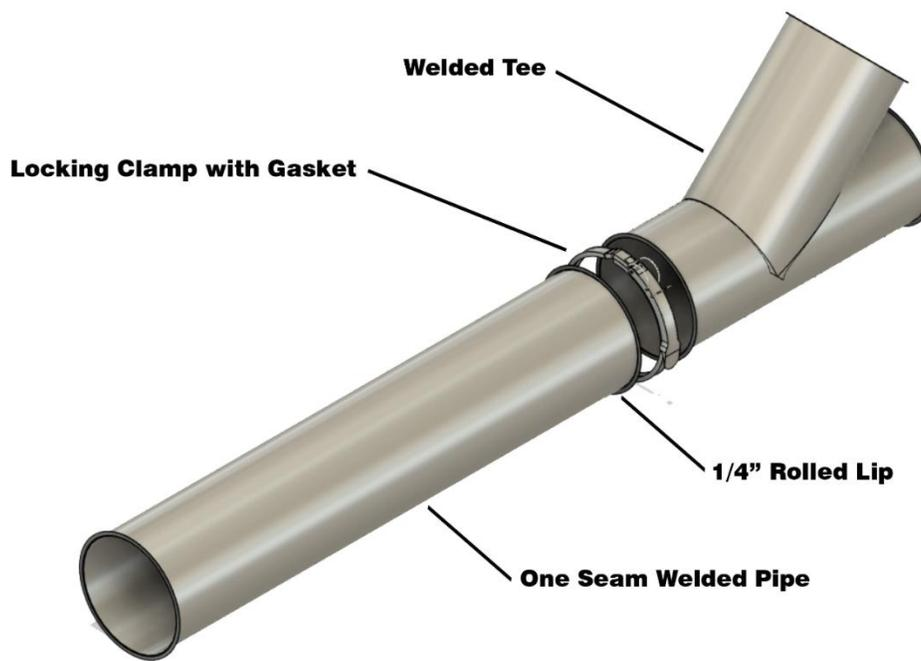

Dust Duct 203

WELDED PIPE ONE SEAM with Welded Connections

Pressure Class Rating: Negative 10" Water Gauge Max

Sizes Available: 3" through 38"

Lengths Available: 6" through 59"

Material Available: Standard Galvanized G90, however 304, 316 stainless steels and black iron materials are available.

Fabrication: Sheets of metal are cut per diameter stretch out at 5' lengths. Then rolled into desired diameters, creating a solid round tube with one longitudinal seam which is butted up, tack welded on 4 inch centers, and then fully welded. A 1/2" inch flange is rolled out on each end of the pipe and associated fittings, butting the pieces together which then allows for applying a fully welded connection.

Connection: Connections are made by butting up the 1/2" flange out on the pipe and fittings allowing for a fully welded connection.

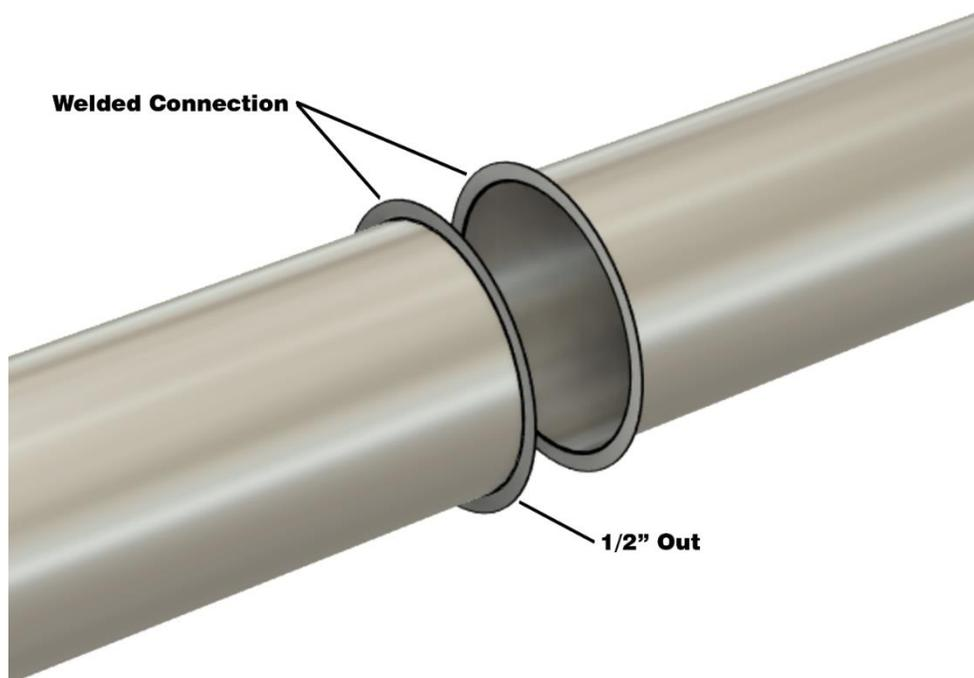

Dust Duct 203

Welded Pipe One Seam with Welded Connection

WELDED ELBOW with Welded Connection

Pressure Class Rating: Negative 10" Water Gauge Max

Sizes Available: 3" through 38"

Material Available: Standard Galvanized G90, black iron, 304 and 316 stainless steels are available.

Fabrication: Elbows are available at any angle. Segmented elbows have a welded transverse seam and a welded longitudinal seam. Radius is standard 1.5x centerline although any radius is available.

Connection: Connections are made by welding two joining pieces together which will have a 1/2" flange out.

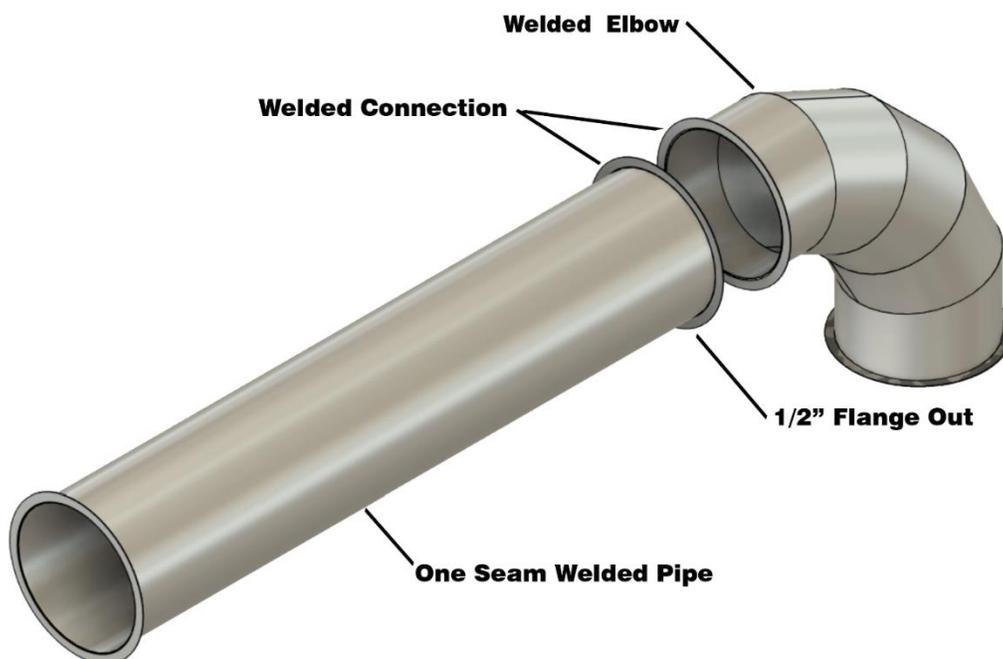

Dust Duct 203

Welded Pipe One Seam with Welded Connection

WELDED REDUCER with Welded Connection

Pressure Class Rating: Negative 10" Water Gauge Max

Sizes Available: 3" through 38"

Material Available: Standard Galvanized G90, black iron, 304 and 316 stainless steels are available.

Lengths Available: Length of the reducer is determined by the set of the reducer. Length is equal to 3 times the largest set, 4" minimum.

Fabrication: Reducers are made with welded longitudinal seams and with welded collars. Standard reducers are concentric, however eccentric and offsetting reducers are available.

Connection: Connections are made by welding two joining pieces together which will have a 1/2" flange out.

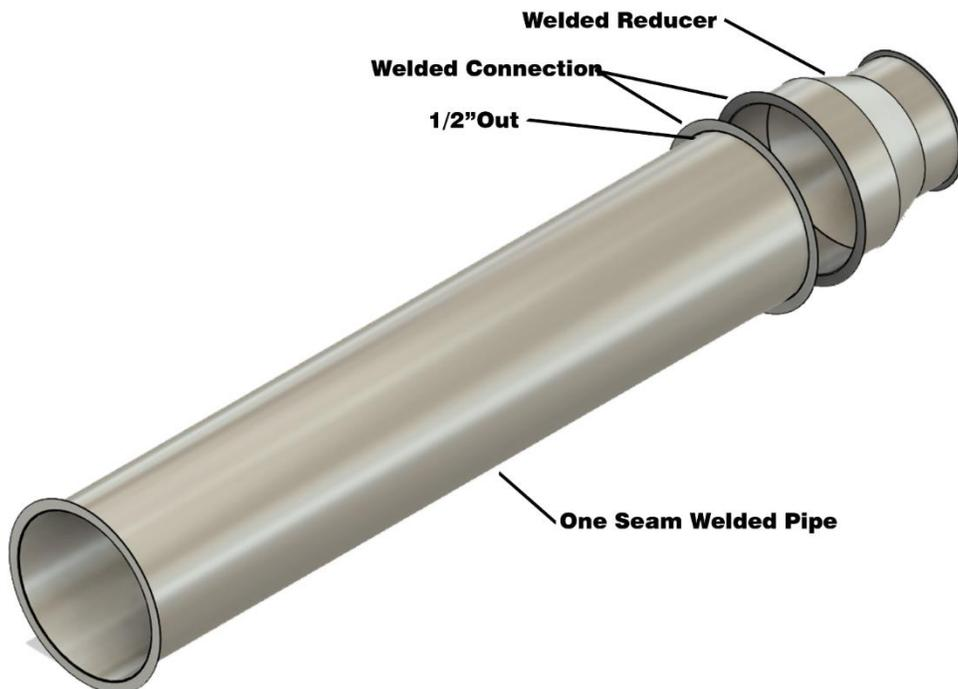

Dust Duct 203

Welded Pipe One Seam with Welded Connection

FULL BODY TAKEOFF with Welded Connection

Pressure Class Rating: Negative 10" Water Gauge Max

Sizes Available: 3" through 38"

Material Available: Standard Galvanized G90, black iron, 304 and 316 stainless steels are available.

Lengths Available: Length of tees and crosses are determined by the diameter of the branch.

Fabrication: Lateral 45 degree tees and crosses are the typical side take off, however branches can come off at any angle. Tees and crosses have welded seams. This fitting can be used to reduce the system's main truck line.

Connection: Connections are made by welding two joining pieces together which will have a 1/2" flange out.

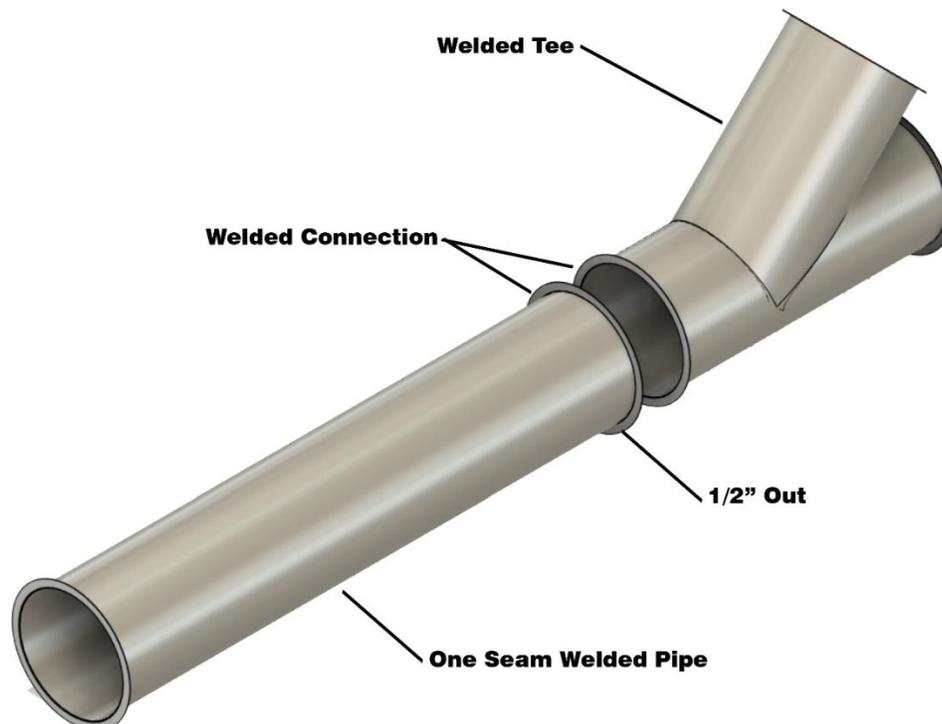

Dust Duct 204

WELDED PIPE ONE SEAM with Angle Ring Connections

Pressure Class Rating: Negative 30" Water Gauge Max

Sizes Available: 3" and up

Lengths Available: 6" through 60"

Material Available: Standard Galvanized G90, Black Iron, 304 and 316 stainless steels are available.

Fabrication: Sheets of metal are cut per diameter stretch out at 5' lengths. Then rolled into desired diameters, creating a solid round tube with one longitudinal seam which is butted up, tack welded on 4 inch centers, and then fully welded.

Connection: Angle rings are tack welded on the straight pipe. Angle rings have pre punched bolt holes. Connections are made by using neoprene gasket between joining flanges and bolting them together. Angle rings are available to match the ductwork material.

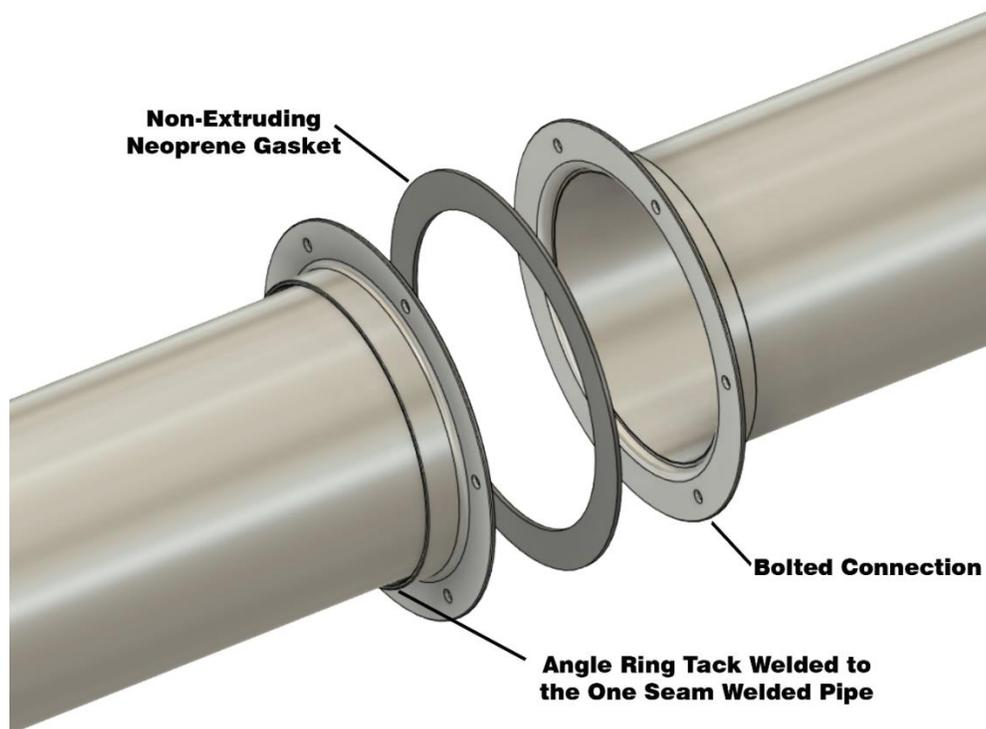

Dust Duct 204

Welded Pipe One Seam with Angle Ring Connection

WELDED ELBOW with Angle Ring Connection

Pressure Class Rating: Negative 30" Water Gauge Max

Sizes Available: 3" and up

Material Available: Standard Galvanized G90, black iron, 304 and 316 stainless steels are available.

Fabrication: Elbows are available at any angle. Segmented elbows have a welded transverse seam and a welded longitudinal seam. Radius is standard 1.5x centerline although any radius is available.

Connection: An angle ring will be held on the connection of the elbow with a ½" Vanstone flange. This keeps the angle ring in place but also allows it to spin freely to line it up with the pre punched bolt holes of connecting piece. Neoprene gasket is used between the two joining rings and then the rings are bolted together.

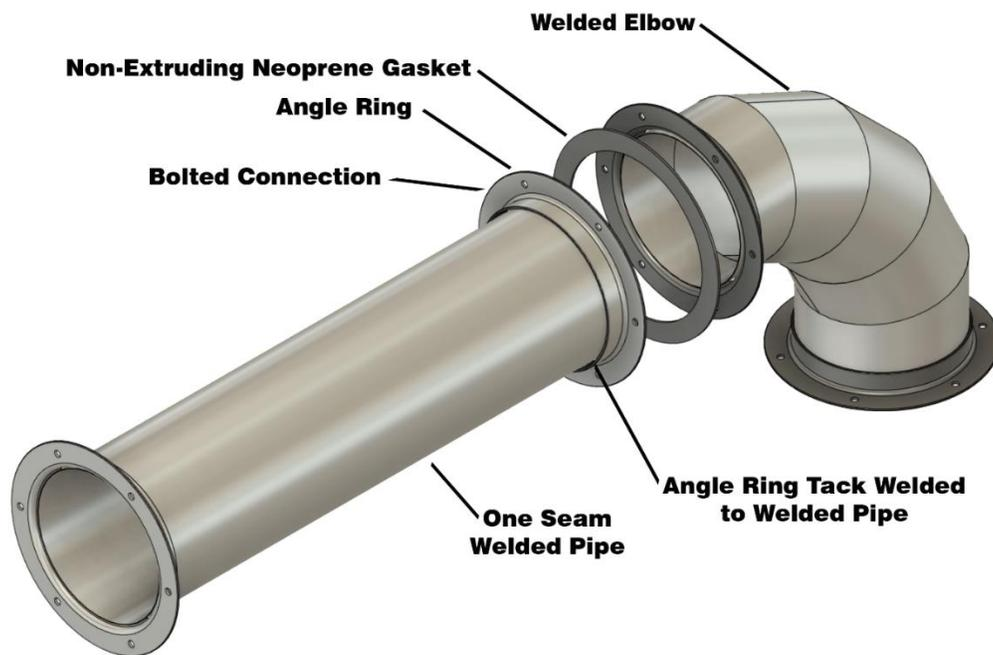

Dust Duct 204

Welded Pipe One Seam with Angle Ring Connection

WELDED REDUCER with Angle Ring Connection

Pressure Class Rating: Negative 30" Water Gauge Max

Sizes Available: 3" and up

Material Available: Standard Galvanized G90, black iron, 304 and 316 stainless steels are available.

Lengths Available: Length of the reducer is determined by the set of the reducer. Length is equal to 3 times the largest set, 4" minimum.

Fabrication: Reducers are made with welded longitudinal seams and with welded collars. Standard reducers are concentric, however eccentric and offsetting reducers are available.

Connection: An angle ring will be placed on the ends of the reducer with a ½" Vanstone flange. This keeps the angle ring in place but also allows it to spin freely in order to line up the pre punched bolt holes. Neoprene gasket is used between two joining rings and then the rings are bolted together.

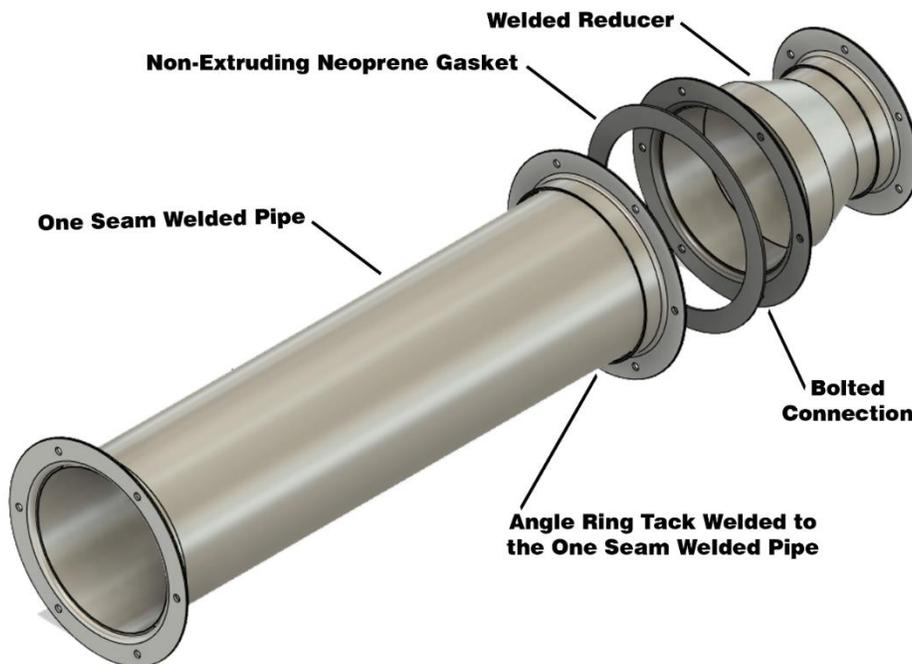

Dust Duct 204

Welded Pipe One Seam with Angle Ring Connection

FULL BODY TAKEOFF with Angle Ring Connection

Pressure Class Rating: Negative 30" Water Gauge Max

Sizes Available: 3" and up

Material Available: Standard Galvanized G90, black iron, 304 and 316 stainless steels are available.

Lengths Available: Length of tees and crosses is determined by the diameter of the branching duct.

Fabrication: Lateral 45 degree tees and crosses are the typical side take off, however branches can come off at any angle. Tees and crosses have welded seams. This fitting can be used to reduce the system's main truck line.

Connection: An angle ring will be placed on the ends of the tee with a ½" Vanstone flange. This keeps the angle ring in place but also allows it to spin freely in order to line up the pre punched bolt holes. Neoprene gasket is used between two joining rings and then the rings are bolted together.

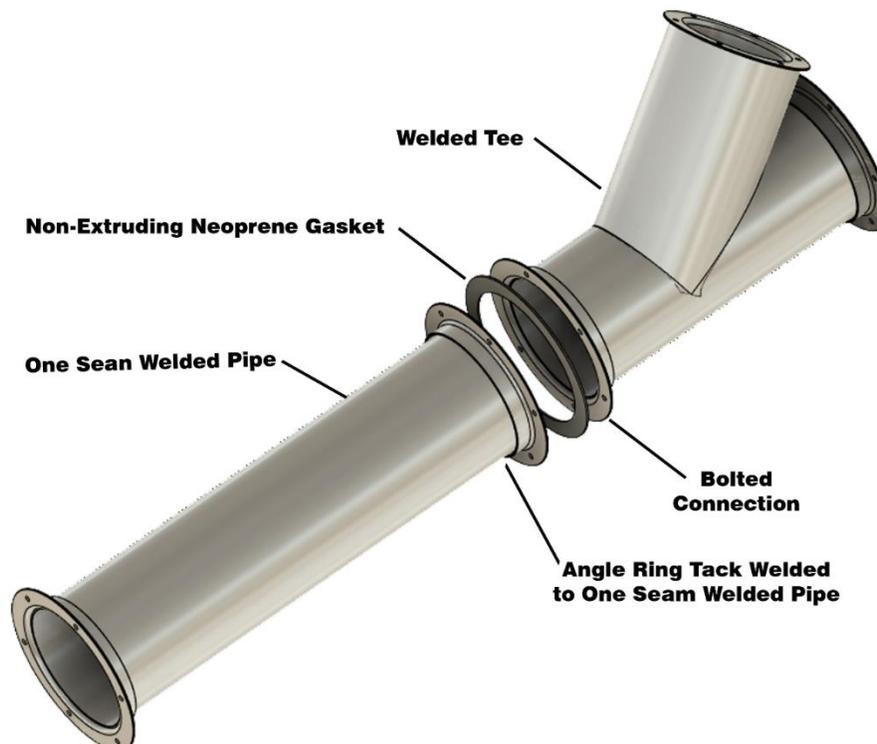

Dust Duct Blast Gates

Blast Gates close off branch lines not in use, as well as controlling the suction of the system at particular points. Blast gates are fabricated to match the duct material of the system. Blast gates are heavy gauge and are designed to slip into nominal duct sizes. Blast gates are available in full or half sizes.



Full Blast Gate



Half Blast Gate

Dust Duct Floor Sweeps

Floor sweeps offer an easy way to clean up waste by sweeping it right into your dust collection system. Floor sweeps are available with accessible foot latch or with an open face model that requires a blast gate closure when not in use.



Dust Duct Flexible Ducts (Hoses)

Flexible Duct Hoses provide adjustable final connections and allow for slight variations if equipment requires movement. Hoses are made from heavy duty rubber.



Dust Duct Pressure Testing

Dust Duct has been pressure tested to ensure that it can withstand required specified pressures.

Duct Leakage Test Data

Project Name: Dust Collector (Duct Collector Ductwork) Required Test Pressure: 10" WC Leakage Class: A
 System Type: Dust Duct Duct Construction Class: 2 Leakage Factor (CFM/100 sg ft): 8.9

Test Section(s)	Duct Size (in.)	Surface Area (sq. ft.)	Allowable Leakage (cfm)	Actual Test Pressure (in.wg.)	Orifice Diameter (in.)	Orifice Coefficient	Orifice Pressure Drop (in.wg.)	Measured Leakage Rate (cfm)	Pass/Fail
DD101	4	21	2	-10	1	13.64	0.01	1	Pass
DD101	12	63	6	-10	1	13.64	0.11	5	Pass
DD101	18	108	10	-10	1	13.64	0.36	8	Pass
DD102	4	21	2	-10	1	13.64	0.01	1	Pass
DD102	12	63	6	-10	1	13.64	0.11	4	Pass
DD102	18	108	10	-10	1	13.64	0.36	7	Pass
DD103	6	31	3	-20	1	13.64	0.02	2	Pass
DD103	24	126	11	-20	1	13.64	0.5	10	Pass
DD103	48	251	22	-20	1	13.64	1.2	15	Pass
DD104	6	31	3	-20	1	13.64	0.02	1	Pass
DD104	24	126	11	-20	1	13.64	0.5	9	Pass
DD104	48	251	22	-20	1	13.64	1.2	13	Pass
DD201	3	16	1	-10	1	13.64	0.01	1	Pass
DD201	12	63	6	-10	1	13.64	0.08	5	Pass
DD201	18	94	8	-10	1	13.64	0.1	7	Pass
DD202	3	16	1	-10	1	13.64	0.01	1	Pass
DD202	12	63	6	-10	1	13.64	0.08	4	Pass
DD202	18	94	8	-10	1	13.64	0.1	6	Pass
DD203	3	16	1	-10	1	13.64	0.01	1	Pass
DD203	12	63	6	-10	1	13.64	0.08	3	Pass
DD203	18	94	8	-10	1	13.64	0.1	4	Pass
DD204	6	31	3	-30	1	13.64	0.02	2	Pass
DD204	24	126	11	-30	1	13.64	0.5	10	Pass
DD204	48	251	22	-30	1	13.64	1.2	17	Pass

Dust Duct CAD Drawings

Each Dust Duct order will include an AutoCAD generated drawing(s). This allows the contractor to thoroughly check the pieces of Dust Duct to ensure accuracy. All drawings will have each piece of duct numbered correlating with the actual piece of duct. This provides an easy install for the contractor.

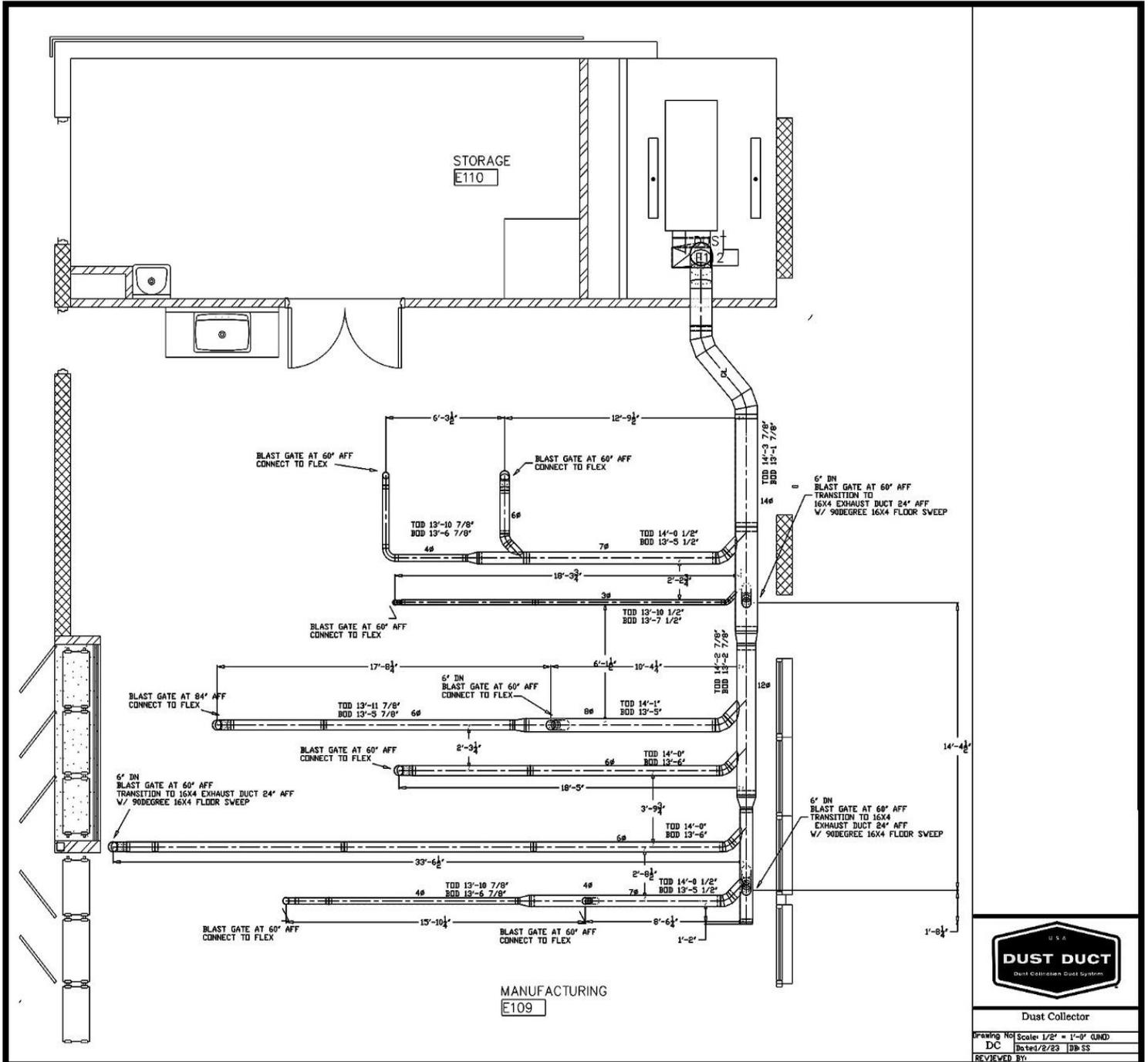

Dust Collector
 Drawing No: Scale: 1/2" = 1'-0" OMD
 DC Dated: 2/23/23 BB SS
 REVIEWED BY:



This features Dust Duct installed in a manufacturing plant in Ohio.



Dust Duct Systems

25 S&T Drive

McClellandtown, PA 15458

(412) 582-1996

